



## Two New Militarized Oscilloscopes Having Both Horizontal and Vertical Plug-Ins

**T**O fill the need for modern, high-performance oscilloscopes in rugged-environment situations such as flight-line and shipboard usage, two new oscilloscopes of the high-frequency class have been designed. One operates from dc to 30 megacycles, the second from dc to 15 megacycles. Both have been designed to operate through such environmental conditions as MIL vibration and shock tests, temperatures up to 50°C, humidities up to 95%, and altitudes up to 10,000 feet.

In addition to advancements in ruggedness, the new oscilloscopes include a number of electrical advancements, the most notable being that plug-in units have been designed for the oscilloscopes' horizontal axis as well as the vertical axis. Through this arrangement it has

been possible to give these oscilloscopes a new level of flexibility, since horizontal-axis plug-in units have been devised that give new functions to the horizontal system. For example, one new plug-in unit, the Display Scanner, enables the oscilloscopes to be used with X-Y recorders to reproduce the display on paper, the difference in speed between oscilloscope and recorder notwithstanding.

A second new horizontal plug-in is a sweep delay generator which has new features for greater flexibility in delayed sweeping. Still another generates intensity modulation markers so as to facilitate such measurements as rise and fall times.

A full series of vertical plug-ins has also been designed.

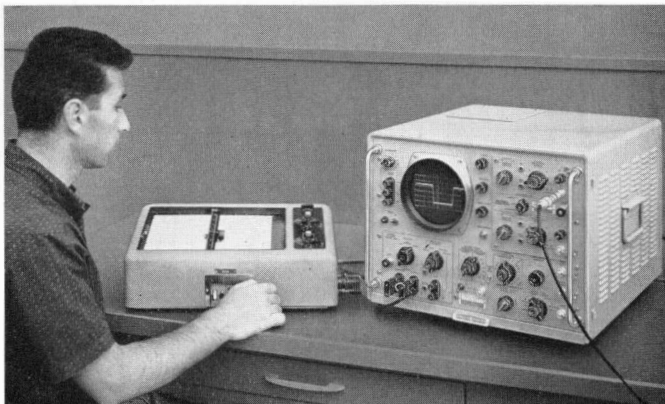

*Fig. 1. New -hp- militarized oscilloscopes are designed with plug-in units for horizontal as well as vertical system, thus achieving increased flexibility. Illustration shows oscilloscope being used with one type of horizontal plug-in that enables oscilloscope display to be recorded on external X-Y recorder.*

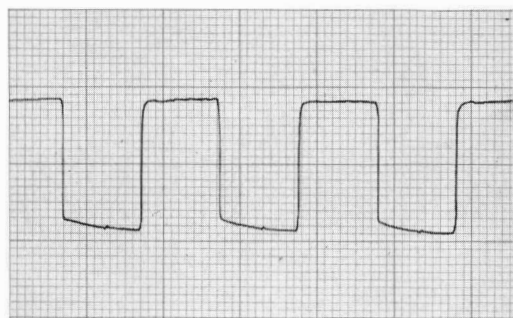

*Fig. 2. Portion of typical X-Y record made using one of new oscilloscopes with Display Scanner horizontal plug-in.*

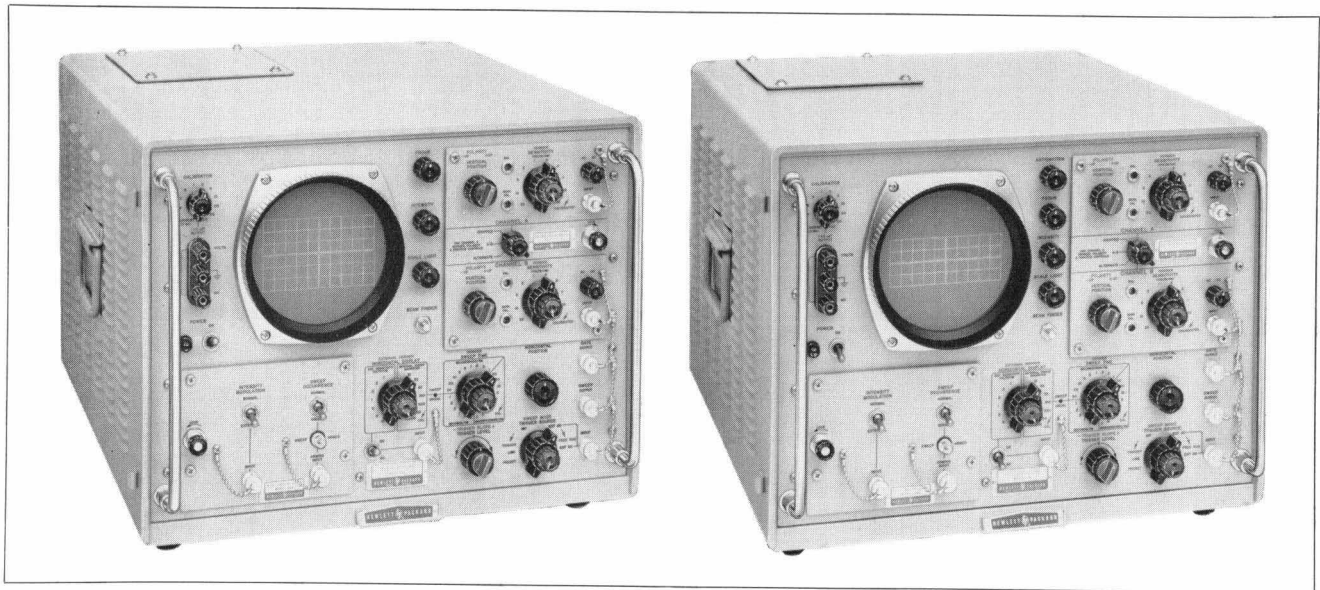

Fig. 3. New -hp- Model 160B 15-megacycle oscilloscope (at left) and Model 170A 30-megacycle oscilloscope (at right) have been designed for rugged-environment usage following MIL specifications as shown in Table II. Horizontal plug-ins fit at lower left of panel, vertical plug-ins at upper right.

By following a design approach in which various auxiliary functions of the oscilloscopes are incorporated into plug-ins, the basic oscilloscopes become adaptable to changing requirements. For example, if not originally needed, the delayed sweep feature can always be given to the oscilloscopes by the later addition of the appropriate plug-ins. Thus, on the one hand the cost of auxiliary features is saved unless they become actually needed, while on the other hand the basic oscilloscopes are guarded against unsuitability for new or unforeseen applications.

Each of the plug-ins in both the vertical and horizontal series is usable with either of the new oscilloscopes. The characteristics that are obtainable from the various combinations of plug-ins and scopes are shown in Table I.

#### ENVIRONMENTAL SPECIFICATIONS

The overall design guide for the new oscilloscopes and their associated plug-ins has been Military Specification MIL-E-16400, and all units pass a rugged series of environmental tests based on that specifica-

tion. A summary of these tests is shown in Table II (p. 7). The environmental specifications listed in Table II are actually part of the instrument specifications on the same basis as electrical specifications, such as bandwidth, sensitivity, etc. Sample testing has been performed periodically to give assurance that the specifications will be met. Complete details of the test procedures are listed in a separate publication.\*

#### SIMPLIFIED CIRCUITRY

A major objective in the design of the new oscilloscopes was to simplify basic oscilloscope circuitry so as to achieve greater reliability. The most significant outcome of this effort was the development of a simplified main vertical amplifier system—one that uses simple "lumped" amplifier stages and fixed delay ca-

\*"Environmental Specifications for the 160B, 170A, etc." Available on request.

TABLE I  
LIST OF PLUG-IN UNITS

MODEL	BANDWIDTH		MAX. SENSITIVITY	NO. OF CHANNELS
	IN 170A	IN 160B		
162A	22 Mc	14 Mc	20 mv/cm	2
162D	18 Mc	12 Mc	5 mv/cm — 20 mv/cm	1
	22 Mc	14 Mc	50 mv/cm and above	
162F	30 Mc	15 Mc	50 mv/cm	1

HORIZONTAL PLUG-IN UNITS	
MODEL	PRIMARY FUNCTION
166A	Provides for external intensity modulation and for normal or single-shot sweeping; supplied as part of the basic oscilloscope.
166B	Provides .1 $\mu$ sec, 1 $\mu$ sec and 10 $\mu$ sec intensity markers to facilitate rise time measurements.
166C	Provides X and Y outputs for duplicating oscilloscope trace on an X-Y recorder.
166D	Provides calibrated delay of main sweep from 1 $\mu$ sec to 10 sec.

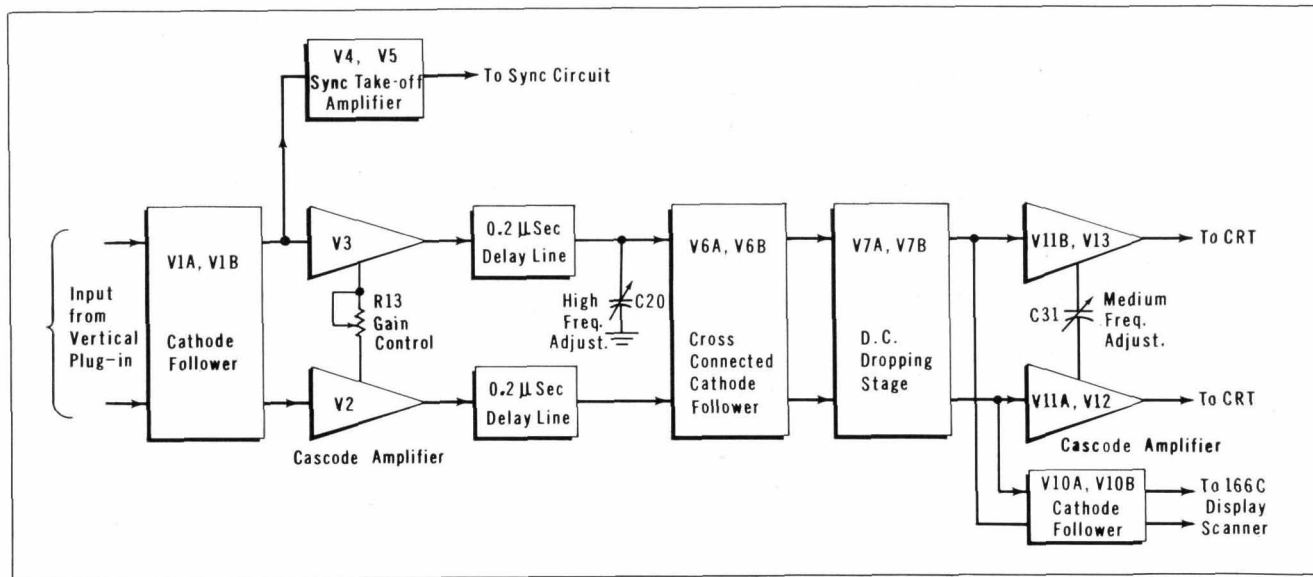

Fig. 4. Main vertical amplifier in new Model 170A oscilloscope uses cascode amplifiers and fixed delay lines to achieve increased oscilloscope simplicity and reliability. Amplifier has only three adjustments as shown.

bles instead of the conventional distributed amplifier stages and multi-section, tunable delay lines usually associated with previous wide-band designs of 15 megacycles and greater. The new "lumped" amplifiers have the advantage that they require only about one-half the usual number of vacuum tubes and that they eliminate the need for delay line adjustments.

The new circuit approach is perhaps best illustrated by the main vertical amplifier of the Model 170A, as shown in Fig. 4, since the overall bandwidth of this unit with preamplifier is 30 megacycles. For the amplification stages the cascode type circuit has been selected because its high gain and low input and output capacity make it well-suited for 30-megacycle application. In addition, the circuit is simple, requires a minimum number of tubes, and enables a rugged frame-grid triode, the 6DJ8, or its MIL counterpart, the 6922, to be used.\*

\*In both of the oscilloscopes and in the plug-ins the design has been centered primarily on the frame-grid triode (6DJ8) to take advantage of that tube's characteristics. As a result, over 70% of the tubes in the new scopes are of this one type. Tube reliability has been further enhanced by operating nearly all tube filaments from a regulated dc voltage.

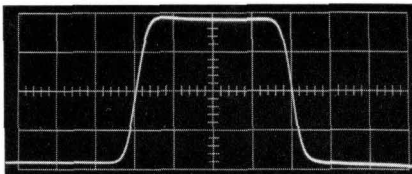

Fig. 5. Typical pulse response of main vertical amplifier in new Model 170A 30-megacycle oscilloscope. Sweep time is 20 nanoseconds/cm.

A further advantage of the cascode stage is that its low output capacity and high shunt resistance make it convenient to drive the delay line and crt plates with minimum loss of signal. Use of the cascode approach also makes it possible to parallel the input tubes of the final stage while using a single output tube. In this way the final stage gain is almost doubled while output capacity is held low for driving the crt plates.

The signal delay lines consist of 5 feet of 950-ohm helical delay-line cable. Losses in this type of line are somewhat greater than in a multi-section LC line, but these are easily compensated for in the amplifier stages. On the other hand, the fixed delay line gives the advantages of a

line that needs no adjustment, is not affected by vibration and corrosion, and contains no exposed high dc potentials.

The overall pulse response obtained with a typical main vertical amplifier of the new design is shown in Fig. 5. Rise time is in the order of 10 nanoseconds, while ringing and overshoot are less than 1%. Calibration of the gain and pulse response of the entire main vertical system is accomplished with the three controls shown in Fig. 4. The complete circuit requires only 11 tubes.

#### OTHER CIRCUIT INNOVATIONS

Another important objective in the development of the new Models 160B and 170A was to make use of the advantages of transistors and other new types of semiconductors to the fullest extent, while at the same time recognizing that in many applications vacuum tubes, because of particular performance characteristics and lower cost, are more suitable. A significant outcome of this approach was the development of the tube-transistor hybrid circuit used in the Model 162A Dual Chan-

nel vertical plug-in amplifier and in the horizontal amplifier. This circuit, shown in Fig. 6, utilizes the high input impedance of a triode and at the same time provides additional gain through the associated transistor. Consequently, the circuit gives many of the advantages of a pentode amplifier while still employing a triode. In addition, the dc level shift through a stage is only 3 volts compared to approximately 60 volts for a vacuum tube stage. This simplifies the requirements of the power supply and allows most of the tube cathodes to operate near ground potential, thereby minimizing the danger of heater-cathode shorts.

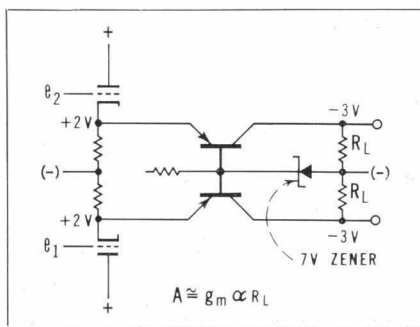

Fig. 6. Basic hybrid circuit used in dual-channel vertical preamplifier and in horizontal amplifier.

Performance-wise, the tube-transistor stages provide a very high gain-bandwidth product. When used with the Model 170A oscilloscope, the circuit of the Model 162A plug-in provides 22 megacycles bandwidth at 20 mv/cm sensitivity with a rise time of less than 16 nanoseconds. Typical overall step response of the 162A-170A combination is shown in Fig. 7.

In the low-voltage power supply it was practical to use silicon rectifiers and transistor regulators, thus allowing the circuit to be completely solid state. The circuit is insensitive to loading to the extent that plug-ins may be changed without turning the instrument off. In addition, the supply voltages stay

(Continued on page 6)

## HORIZONTAL

A total of four horizontal-type plug-ins have presently been designed. Any of these may be used with either oscilloscope. Despite the fact that they are known as "horizontal plug-ins" so as to distinguish them from the regular vertical system, their function is not necessarily limited to the horizontal axis. One of the units, for example, provides output signals from the vertical as well as the horizontal system to operate an external recorder. Also, the basic sweep circuits themselves are located in the main part of the scopes and not in the plug-ins, although a number of features of the plug-ins add to the flexibility of the basic sweep circuits such as providing for delayed sweeping.

### MODEL 166A AUXILIARY PLUG-IN

Of the four horizontal plug-ins one is a standard accessory and is supplied with each oscilloscope. This unit is the Model 166A Auxiliary Plug-In shown in place in the oscilloscopes pictured in Fig. 3. The 166A provides for intensity modulation from external sources and for normal or single-shot sweeping.

### MODEL 166B MARKER GENERATOR

To facilitate measurement of rise time and other important time intervals, the Model 166B provides accurately calibrated intensity markers on the oscilloscope trace. Markers are available at 10  $\mu$ sec, 1  $\mu$ sec and 0.1  $\mu$ sec intervals, accurate to  $\pm 0.5\%$ , and synchronized to the signal being displayed.

In a second mode of operation, markers are available in a continuous train at a front panel jack. In this form, they are useful for calibrating the sweeps of the 160B and 170A or external equipment.

A series of accurately tuned LC circuits, coupled to a Hartley Oscillator, provide the basic timing waveform. In the "display" mode, the oscilloscope gate acts on a transistor switch to start and stop oscillations in synchronism with the main sweep. In the "Output" mode, the switch is biased on and

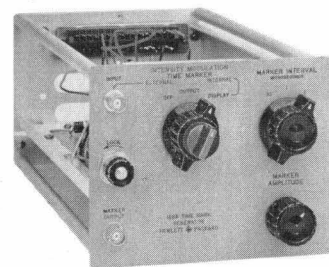

Model 166B

oscillations are continuous.

The  $\pm 0.5\%$  accuracy applies from 0° to 50°C. From -28°C to 0°C accuracy is  $\pm 1\%$ .

### MODEL 166C DISPLAY SCANNER

The Display Scanner samples a repetitive trace appearing on the oscilloscopes and translates it into two low frequency signals suitable for driving X-Y recorder. The regular five-inch oscilloscope display can thus be reproduced in large X-Y recorder plots with improved resolution and convenience. The trace shown in Fig. 2 (first page) from a decade divider illustrates the potential of the 166C for use in report writing, production, test, teaching, and other areas where high quality reproductions are required.

The Display Scanner uses the same sampling principles employed in the -hp- Model 185A Sampling Oscilloscope, although the circuits have been scaled down since they only have to handle 30 Mc bandpass capability of the 170A and always operate on periodically repetitive traces. The basic operation is the sampling of voltage amplitudes of the trace at slowly progressing points across the screen which results in a "slowed down" reproduction of the original signal. The scanning ramp of the Display Scanner can be operated in a mode in which the slope is controlled by the input waveform with the result that the X-Y recorder may operate at nearly constant pen speed. This feature permits the fastest possible reproduction speed with the limited bandpass of most X-Y recorders.

# PLUG-INS

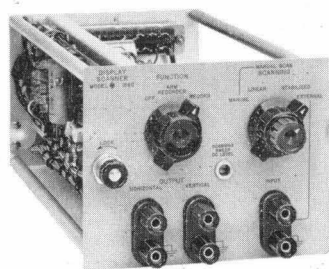

Model 166C

Four methods are provided for scanning. In "linear scan," a linear ramp is generated by a Miller integrator in the Display Scanner. Each time the oscilloscope sweep recurs, a sample of the input waveform is taken as the oscilloscope's main sweep and the slow ramp coincide. Each sample is taken at a slightly later time in relation to the start of the main sweep with the result that the scanning point progresses through the waveform from left to right as displayed on the oscilloscope trace. A small portion of the sampling pulse is coupled into the oscilloscope amplifier to provide a marker on the trace denoting the sampling point.

In the "stabilized" mode, operation is the same except that the slope of the ramp is modulated by the input signal. This is done in such a way that the X-axis signal slows down on steep wave-fronts, resulting in a combined X- and Y-drive to the X-Y recorder which gives approximately constant pen speed. "Manual Scan" and "External Scan" facilities are provided so that the scanning point may be programmed by a variety of signals.

The time for producing a trace in "linear scan" is approximately 90 seconds. In "stabilized scan" the time depends on the shape of the particular waveform, with the minimum being approximately 25 seconds.

In addition to its primary capability of providing for the reproduction of oscilloscope traces by X-Y recorders, the Display Scanner is potentially a very useful device for automatic checkout applications. Waveforms displayed on the oscilloscope can be scanned in discrete steps, for example,

and the Y-axis output can be fed to a simple digital voltmeter. The voltmeter readings could be permanently recorded for later study, or could be used for a continuous "go-no-go" check on the quality of the waveform.

## MODEL 166D SWEEP DELAY GENERATOR

The Sweep Delay Generator gives a variety of sweep delay features to the basic oscilloscopes. Through its use, time relationships on complex signals or pulse trains can be conveniently and accurately measured.

The basic operation of the 166D involves the generation of a linear ramp which, in conjunction with a pick-off circuit, generates a trigger which can be used either to arm or actually start the main sweep after a selected time interval.

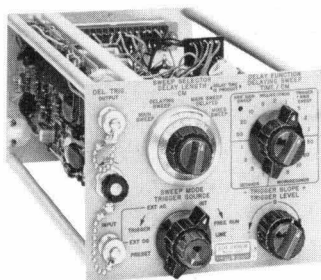

Model 166D

The selector on the panel of the unit provides for four different types of operation. With the sweep selector in the "main sweep" position, the oscilloscope operates in the normal manner using the main sweep controls. In "delaying sweep" operation, trigger and sweep control are transferred to the Sweep Delay Generator which then drives the trace across the crt in accordance with the setting of the delay controls. When the ramp becomes equal to the value selected by the Delay Length pick-off control, the main sweep is triggered (or armed) and appears as an intensified segment of the trace.

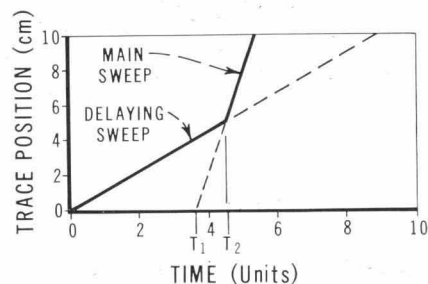

The "main sweep delayed" position differs from the previous position in that the delaying sweep output is not fed to the horizontal crt plates which instead are driven by the main sweep. Thus, the brightened section, which appeared in the "delaying sweep" position, is expanded to occupy the entire 10 cm of the CRT face.

In the special "mixed sweep" position, illustrated in the drawing, the delaying sweep drives the trace for the selected delay interval, at which time the main sweep is triggered (or armed). At some later time, determined by the amount of the delay interval and the relative slopes of the two sweeps, the main sweep will overtake the delaying sweep and drive the beam for the remainder of the trace. The advantage of this mode of operation is that the operator can view the expanded portion of the trace while still retaining a presentation of earlier sections. A typical application is shown in the oscillogram which illustrates the waveform from the memory drum of a digital computer. The sweep is triggered once for each drum rotation. The entire word pattern around the drum can then be examined in sequence, while portions of the pattern preceding the word of interest are always retained on screen.

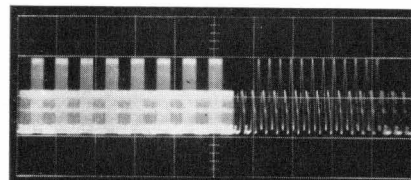

(Continued from page 4)

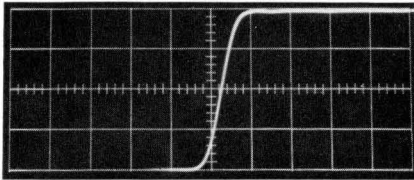

Fig. 7. Typical overall step response of Model 162A pre-amplifier used with Model 170A oscilloscope. Sweep time is 20 nanoseconds/cm.

within safe values during turn-on so that a time delay relay is not required.

#### MILITARY DESIGN

Both new oscilloscopes have evolved from the AN/USM-105A 15-megacycle oscilloscope developed for the Navy's Bureau of Ships. Specification MIL-E-16400 mentioned earlier and its associated subsidiary specifications were carefully followed for the overall design of the new oscilloscopes. Similarly, to the extent permitted by the objectives of modern, high-performance design, component types used in the instruments were selected from the

Qualified Products List. In general, components not selected from the Qualified Products List meet or surpass the appropriate MIL specification for the component type.

#### OPTIONAL STYLES

Because of the high cost of certain QPL type parts, particularly tubes and semiconductors, the new oscilloscopes have been made available in two options. In the "HO2" option, part types are the same as in the AN/USM-105A. In the standard option, less expensive tubes and

## VERTICAL PLUG-INS

A series of three plug-ins has been designed for the vertical systems of the new oscilloscopes, any of the three being usable in either instrument. As a group these three units provide all of the functions normally associated with the vertical system of sophisticated oscilloscopes. Like the other plug-ins, the vertical plug-ins meet the environmental tests described in the main article.



**MODEL 162A DUAL TRACE AMPLIFIER**

The Model 162A provides high sensitivity and dual channel capability for both the 160B and the 170A. Sensitivity is 20 mv/cm and a selection of alternate, chopped, or differential input modes is provided. In the differential mode, common mode rejection is at least 40 db at maximum gain and 30 db when using the attenuators. A

high chopping rate of 1 mc is provided to increase the readability of the 2-channel display on transients and low repetition rate signals. Trace blanking is provided during the switching interval.

The amplifier in this plug-in is a tube-transistor hybrid circuit of the type described in the accompanying article. Regulated DC filaments throughout the 162A help to minimize hum, increase tube life, and provide better gain stability.

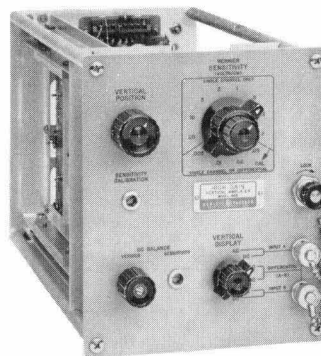

**MODEL 162D HIGH GAIN VERTICAL AMPLIFIER**

Model 162D High Gain Amplifier provides wide bandwidth and high gain in the 160B and 170A. The unit is DC coupled on all ranges, has 5 mv/cm sensitivity, and provides differential input for the 4 most sensitive ranges with at least 40 db common

mode rejection. Bandwidth is 18 Mc in the 170A and 12 Mc in the 160B in the high sensitivity settings and 22 and 14 Mc, respectively, in the lower sensitivity settings.

The primary circuit in Model 162D is a two-stage common emitter transistor amplifier with an overall gain of 40. Heavy negative feedback provides excellent gain stability. Cathode followers are used to couple the signal in and out of the preamplifier.

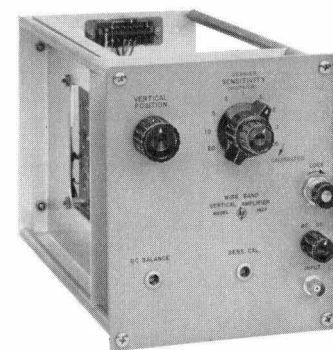

**MODEL 162F FAST RISE AMPLIFIER**

The Model 162F is a simple, low cost, single channel preamplifier that provides maximum frequency response in the 170A and 160B. When used with the 170A, the overall bandwidth is 30 megacycles, giving a combined rise time of 12 nanoseconds. The unit gives a maximum sensitivity of 50 millivolts/cm.

semiconductors are substituted for QPL types in certain circuits. These substitutions cause no deterioration in either the electrical or environmental performance specifications.

#### FUTURE PLUG-INS

The two plug-in approach in the design of the new oscilloscopes makes possible a wide variety of special features, and several other plug-ins are currently under development. Since the horizontal plug-in connector provides access to such signals in the main part of the oscil-

losopes as the main vertical amplifier signal, the main sweep signal, the horizontal amplifier, the crt grid, the gate signal, all power supply voltages, and several other signals, the oscilloscopes are insured against obsolescence that might be created by improved circuitry or by new and different measuring requirements.

#### ACKNOWLEDGMENT

The design and development of the 160B-170A oscilloscopes and various plug-ins was a joint effort of a number of individuals in the -hp-

Oscilloscope Research Division. Included in the group were Al F. Augustine, Ralph H. Britton, Robert L. DeVries, Phillip G. Foster, Robert E. Heller, Don L. Palmer, Floyd G. Siegel, Allen R. Smith, Theodore W. Statler, John H. Strathman and John G. Tatum. Jerald R. Chamberlain and James E. O'Briant ably contributed to the environmental testing program, and a number of valuable ideas and suggestions were contributed by Norman B. Schrock.

-George F. Fredrick

**TABLE II**  
**SUMMARY OF ENVIRONMENTAL SPECIFICATIONS**  
**FOR MODELS 160B, 170A and PLUG-IN UNITS**

TEST	GUIDING MIL SPECIFICATION	BRIEF DESCRIPTION
Preconditioning	MIL-T-945	Storage from $-65^{\circ}\text{C}$ ( $-85^{\circ}\text{F}$ ) to $85^{\circ}\text{C}$ ( $185^{\circ}\text{F}$ ) at altitudes up to 50,000 feet (3.4" Hg).
Temperature, Humidity and Altitude	MIL-E-16400	Satisfactory operation from $-28^{\circ}\text{C}$ ( $-18^{\circ}\text{F}$ ) to $50^{\circ}\text{C}$ ( $122^{\circ}\text{F}$ ) at altitudes up to 10,000 feet (20.6" Hg) and under humidity up to 95%.
Vibration	MIL-T-945	Vibration with 0.060" excursion 10 to 33 cps and 0.030" excursion 10 to 55 cps, three principal axes. Three minute vibration at each of the 4 most severe resonant frequencies.
Shock	MIL-T-945	Hammer drop blows of 1, 2 and 3 feet, 2 horizontal axes. Blows of 2, 3, and 4 feet on vertical axes.
Drip-proof Test for Combination Case	MIL-T-945	Storage under a 1" diameter spray nozzle in upright position and with 4 sides tilted $15^{\circ}$ from vertical; 5 minute exposure per side with front cover 160B-44A-1 in place.
Salt Spray Test	MIL-T-945 and MIL-E-16400	Parts not covered by MIL-E-16400 or MIL-T-945 shall be given a 100 hour salt spray test per Federal STD No. 151.
Conducted Interference, Radiated Interference, and Susceptibility to Conducted Noise	MIL-I-16910	Tests are conducted as described in MIL-I-16910; limits for portable equipment apply.
Fungus Test	MIL-T-945 and MIL-E-16400	Parts not covered by MIL-E-16400 or MIL-T-945 shall be fungus tested per MIL-T-945.

#### H. ROWAN GAITHER

It is with deep regret that we report the death of one of Hewlett-Packard's most distinguished and able directors, H. Rowan Gaither.

Mr. Gaither's contributions to the national welfare were many and varied. As president of the Ford Foundation, from 1953 to 1958, he took a major role in establishing its character and setting it forward on its path toward greatness. Ill health caused him to resign from this position, but he was still a director at the time of his death. He served his government directly in many ways, most recent of which was as chairman of the Security Resources panel. This group, reporting through President Eisenhower's Science Advisory Committee, authored the so-called "Gaither Report", a critical survey of the Nation's military capability. He was one of the organizers of the RAND Corporation, and currently was serving as chairman of its Board of Trustees. Although a lawyer and banker by profession, he made contributions in the scientific field as assistant director of the Radiation Laboratory at MIT during the war years, for which work he was awarded the Presidential Certificate of Merit.

This country has lost one of its foremost citizens with the passing of Mr. Gaither.

#### SPECIFICATIONS

##### -hp- MODEL 160B OSCILLOSCOPE (with 166A installed)

###### SWEEP GENERATOR

Internal Sweep: 24 ranges, 0.1  $\mu\text{sec}/\text{cm}$  to 5  $\text{sec}/\text{cm}$ ;  $\pm 3\%$ . Vernier extends slowest sweep to 15  $\text{sec}/\text{cm}$ .

Magnification: 7 calibrated ranges, x1, x2, x5, x10, x20, x50 and x100. Increases fastest sweep speed to .02  $\mu\text{sec}/\text{cm}$ . Accuracy: x1, x2 and x5,  $\pm 3\%$ ; x10 and x20  $\pm 5\%$  to 0.02  $\mu\text{sec}/\text{cm}$ ; x50 and x100,  $\pm 10\%$  to 0.02  $\mu\text{sec}/\text{cm}$ .

Triggering: Internal, power line or vertical input signal (2mm or more vertical deflection). External (1/2 volt peak-to-peak or more).

Trigger Point: Positive or negative going voltage. Trigger level of external sync signal adjustable  $-30$  to  $+30$  volts.

Sawtooth Output:  $-50$  to  $+50$  volts.

Gate Output:  $+50$  volt pulse.

###### HORIZONTAL AMPLIFIER

Bandwidth: DC to 1 mc.

Sensitivity: 7 ranges 0.1 volt/cm to 10 volts/cm. Vernier extends minimum sensitivity to 25 volts/cm.

Input Impedance: 1 megohm shunted by 30 pf.

###### MAIN VERTICAL AMPLIFIER

Bandwidth Capability: 15 mc.

###### CALIBRATOR

Type: 1000 cycle square wave, 1  $\mu\text{sec}$  rise and decay time.

Voltage: 18 calibrated ranges  $\pm 3\%$ , 0.2 milli-volts to 100 volts peak-to-peak.

Current: 5 ma peak-to-peak,  $\pm 3\%$ .

###### CATHODE RAY TUBE

Type: 5 AMP-mono accelerator, flat face, P1, P2, P7, or P11 screen. 5000-volt accelerating potential.

Filter Supplied: Compatible with phosphor, green with P1 and P2, amber with P7, and

blue with P11.

Graticule: 10 cm long x 6 cm high marked in centimeter squares; 2 mm subdivisions on horizontal and vertical axes. Controlled edge lighting.

Deflection Plate Connection: Pin type terminals. Deflection Sensitivity: 20 volts/cm approximately.

Intensity Modulation:  $\pm 20$  volt pulse will blank CRT trace of normal intensity.

###### GENERAL

Power Requirements: 115/230 vac  $\pm 10\%$ , 50-440 cps, approx. 480 watts.

Color: Grey enamel in accordance with Type III Class 2 of Specification MIL-E-15090.

###### Dimensions:

Cabinet Mount: 14 $\frac{3}{8}$  in. high, 19 in. wide, 22 $\frac{1}{8}$  in. deep.

(Continued on page 8)

## SPECIFICATIONS (Continued from page 7)

Rack Mount: 12¼ in. high, 19 in. wide, 21 in. deep behind panel.

### Weight:

Cabinet Mount: Net 85 lbs., shipping 100 lbs.  
Rack Mount: Net 85 lbs., shipping 100 lbs.

### Accessories Available:

AC-83A Viewing Hood, \$5.00.  
AC-21C Probe, 50:1 voltage divider, \$30.00.  
AC-21F Current Probe, 1 mv/ma, \$100.00.  
AC-67B Feed-through Termination for AC-21F, 2.5 kc to 30 mc, \$17.50.  
AC-67C Compensated Termination for AC-21F, 1.4 kc to 30 mc, \$30.00.  
AC-115B Testmobile, \$85.00.

160B-44A-1 Front Cover (required for drip proofing, does not fit rack mount). Includes two UG-255/U adapters (UHF female to BNC male), two UG-273/U adapters (UHF male to BNC female), two UG-1035/U adapters (dual banana plug male to BNC male), two UG-274A/U connectors (BNC female Tees), and two CG-409E/U Cables (8 feet long, male BNC terminations). The front cover also provides space for the furnished accessories and the instruction manual. Price, \$75.00.

Accessories Furnished: Two AC-21A Probes, 10:1 voltage division. Two AC-76A BNC male to binding post adapters.

Price: With line filter, dc fan and -hp Model 166A. -hp Model 160B (cabinet) or -hp Model 160BR (rack mount), \$1,850.00.

Options: AC fan (50 to 60 cps) in lieu of dc fan, no extra charge.

Detented Tilting Slides for rack mount, specify C99-160BR, add \$85.00.

With all MIL-approved type tubes and semi-conductors (environmental specifications are met with or without this option), specify H02-160B (cabinet), H02-160BR (rack), add \$185.00.

### -hp- MODEL 170A OSCILLOSCOPE

(with 166A installed)

The specifications for the Model 170A are the same as for the Model 160B as given above with the following differences:

#### MAIN VERTICAL AMPLIFIER

Bandwidth Capacity: 30 mc.

#### CATHODE RAY TUBE

Type: 5 BHP Post Accelerator, P1, P2, P7, or P11 screen. 10,000 volt accelerating potential.

Filter Supplied: Compatible with phosphor, green with P1 and P2, amber with P7, and blue with P11.

Graticule: 10 cm long x 4 cm high marked in centimeter squares; 2 mm subdivisions on horizontal and vertical axes. Controlled edge lighting.

Deflection Plate Connection: Pin type terminals. Deflection Sensitivity: 7 volts/cm approximately.

Intensity Modulation: +20 volt pulse will blank CRT trace of normal intensity.

Price: With line filter, dc fan and -hp Model 166A. -hp Model 170A (cabinet) or -hp Model 170AR (rack mount), \$2150.00.

Options: AC fan (50 to 60 cps) in lieu of dc fan, no extra charge.

Detented Tilting Slides for rack mount, specify C99-170AR, add \$85.00.

With all MIL-approved type tubes and semi-conductors (environmental specifications are met with or without this option), specify H02-170A (cabinet), H02-170AR (rack), add \$200.00.

### -hp- MODEL 162A PLUG-IN AMPLIFIER

(with -hp Model 160B or 170A Oscilloscope)

#### EACH CHANNEL

Sensitivity Range: 0.02 volt/cm to 50 volts/cm. Ten calibrated ranges in 1, 2, 5, 10 sequence, from 0.02 volt/cm to 20 volts/cm. Accuracy ±5%.

Vernier extends minimum sensitivity to at least 50 volts/cm.

#### Pass Band:

With -hp- 160B: DC coupled: dc to 14 mc, 0.025  $\mu$ sec rise time. AC coupled: 2 cps to 14 mc.

With -hp- 170A: DC coupled: dc to 22 mc, 0.016  $\mu$ sec rise time. AC coupled: 2 cps to 22 mc.

Input Impedance: 1 megohm (nominal) shunted by 25 pf.

Polarity of Presentation: + up or - up, selectable.

Electronic Switching: By alternate sweep or chopped at approximately 1 mc, with blanking during switching.

#### DIFFERENTIAL INPUT

Both input attenuators may be switched to one channel to give differential input. The input attenuators may be set separately to allow mixing signals of different levels.

Amplifier: Channel A. Amplifier Input A — Input B.

Common Mode Rejection: At least 40 db at maximum sensitivity, at least 30 db when using attenuators.

#### GENERAL

Weight: Net 6 lbs.

Power: Supplied by -hp- Model 160B or 170A Oscilloscope.

Price: -hp- Model 162A Dual Trace Amplifier for 160B or 170A Oscilloscope, \$350.00.

With all MIL-approved type tubes and transistors, specify H02-162A, \$395.00. (Environmental specifications are met with or without this option).

### -hp- MODEL 162D

#### HIGH GAIN VERTICAL AMPLIFIER

Sensitivity: 5 mv/cm to 20 volts/cm in twelve calibrated ranges in a 1, 2, 5, 10 sequence, accuracy ±5%.

Vernier allows continuous adjustment between calibrated ranges, and extends minimum sensitivity to at least 50 volts/cm.

Dual Inputs: Two signal input jacks (BNC). AC or DC coupling of either input selectable with front panel switch. Isolation between inputs at least 80 db.

Differential Input: AC or DC differential input may be selected in the ranges of 5 mv/cm to 50 mv/cm. Common mode rejection at least 40 db. Input voltage rating 600 volts peak.

#### Pass Band:

With -hp- 170A 50 mv/cm and above: dc to 22 mc (DC coupled); 2 cps to 22 mc (AC coupled). 20 mv/cm-5 mv/cm: dc to 18 mc (DC coupled); 2 cps to 18 mc (AC coupled).

With -hp- 160B: 50 mv/cm and above: dc to 14 mc (DC coupled); 2 cps to 14 mc (AC coupled). 20 mv/cm-5 mv/cm: dc to 12 mc (DC coupled); 2 cps to 12 mc (AC coupled).

Input Impedance: Approximately 1 megohm with less than 35 pf shunt capacitance.

Weight: Net 5 lbs.

Power: Supplied by Model 170A or 160B Oscilloscope.

Price: -hp- Model 162D: \$225.00. With all MIL-approved type tubes and transistors, specify H02-162D: \$235.00 (Environmental specifications are met with or without this option).

### -hp- MODEL 162F

#### FAST RISE PREAMPLIFIER

#### Pass Band:

With -hp- 170A DC Coupled: DC to 30 mc, 12 nsec rise time. AC Coupled: 2 cps to 30 mc, 12 nsec rise time.

With -hp- 160B DC Coupled: DC to 15 mc, 23 nsec rise time. AC Coupled: 2 cps to 15 mc, 23 nsec rise time.

Sensitivity: Nine calibrated ranges in 1, 2, 5, 10 sequence from 0.05 v/cm to 20 v/cm. Vernier provides continuous adjustment between ranges and extends minimum sensitivity to at least 50 v/cm.

Attenuator Accuracy: ±3%.

Input Impedance: 1 megohm (nominal) shunted by approximately 22 pf.

Power: Supplied by -hp- Model 160B or 170A Oscilloscope.

Weight: Net 5 lbs.

Price: -hp- Model 162F: \$145.00. With all MIL-approved tubes, specify H02-162F: \$160.00 (Environmental specifications are met with or without this option).

### -hp- MODEL 166B

#### MARKER GENERATOR

#### INTENSITY MODULATION

Range: 10  $\mu$ sec, 1  $\mu$ sec, or 0.1  $\mu$ second intervals.

Accuracy: ±0.5%.

Presentation: Trace-intensifying marks with duration a function of intensity, but always less than 40% of marker interval.

Synchronization: Triggered by sweep gate; synchronized to CRT presentation.

#### EXTERNAL OUTPUT MARKERS

Range: 10  $\mu$ sec, 1  $\mu$ sec, or 0.1  $\mu$ second intervals.

Accuracy: ±0.5%.

Amplitude: 0 to 1 volt peak (positive) into open circuit, adjustable.

Waveform: Positive polarity clipped sine wave with duration a function of amplitude, but always less than 40% of marker interval.

Output Impedance: Approximately 75 ohms.

#### FUNCTIONS

##### Time Marker:

Off—marker de-energized.

Output—markers provided at BNC output jack.

Display—markers provide synchronized intensity modulation of display (Intensity modulation control set to INTERNAL).

Intensity Modulation: External: provide input for normal external intensity modulation.

Internal: allows intensity modulation of trace. (Time markers set to DISPLAY).

Power: Supplied by -hp- Model 160B or 170A Oscilloscope.

Price: -hp- Model 166B: \$130.00. With all MIL-approved type tubes and transistors, specify H02-166B: \$140.00 (Environmental specifications are met with or without this option).

### -hp- MODEL 166C

#### DISPLAY SCANNER

Vertical Output: With 160B: Approximately +0.7 v for 3 cm above middle of crt, -0.7 v for 3 cm below middle of crt.

With 170A: Approximately +0.55 v for 2 cm above middle of crt, -0.55 v for 2 cm below middle of crt.

Horizontal Output: 0 cm, approximately +50 volts; 10 cm, approximately -50 volts.

Bandwidth: 14 mc with 160B/162A; 20 mc with 170A/162A.

Scanning: Manual, internal (with pen speed stabilized or linear) or external.

Scanning Time: Internal linear, approximately 1½ minutes. Internal with pen speed stabilized, approximately 25 seconds when displaying base line only.

Oscilloscope Sweep Speed: From fastest sweep to 5 msec/cm; signal repetition rate greater than 20 cps.

Power: Supplied by -hp- 160B or 170A.

Weight: Net 5 lbs. Shipping 9 lbs.

Price: -hp- Model 166C: \$300.00.

### -hp- MODEL 166D

#### SWEEP DELAY GENERATOR

Delay Time: 1  $\mu$ sec to 10 seconds.

Delaying Sweep: 18 calibrated ranges from 2  $\mu$ sec/cm to 1 second/cm in 1, 2, 5, and 10 sequence.

Delayed Length: 0 to 10 cm. When delaying sweep functions in place of main sweep, setting in cm controls occurrence of main sweep. When delayed main sweep is used, setting acts as multiplier on Delaying Sweep setting to determine total delay time.

Accuracy: ±1% 2  $\mu$ sec to .1 second ranges; ±3% .2, .5, 1 second ranges; ±0.2% linearity, all but 2, 5, and 10  $\mu$ sec ranges; ±5% linearity, 2, 5, 10  $\mu$ sec ranges.

Jitter: Less than 0.01  $\mu$ sec or ±0.005% of total delay.

Delay Functions: (a) Trigger main sweep. (b) Arm main sweep.

Triggering: Internal, power line or vertical input signal. (2 mm or more vertical deflection. External, ½ volt peak-to-peak or more).

Triggering Point: Positive or negative going voltage. Trigger level of external sync signal adjustable -30 to +30 volts.

Sweep Selector: (a) Main Sweep; (b) Delaying Sweep. Brightened segment of trace indicates time relationship between delaying sweep display and main sweep display; (c) Main Sweep Delayed; (d) Mixed Sweep.

Delayed Trigger Output: Approximately 20 volts positive.

Power: Supplied by 160B or 170A.

Weight: Net 4½ lbs. Shipping 7 lbs.

Price: -hp- 166D: \$325.00. With all tubes and transistors MIL approved types, specify H02-166D (environmental specifications are met with or without this option) \$365.00.

Prices f.o.b. factory.

Data subject to change without notice.